

SEPARATOR VESSELS

New Used Sweet Sour

Rev.2 01-06-15

1.0 DESCRIPTION			
Job#	B2102	Date	4-FEB-2019
Diameter	52.6"OD/48"ID	Type	HOR.SEP.
Manufacturer	PLAINS OIL LTD	Length S/S	16'
A#	2937337	Date Built	1994
CRN#	M2091.2	Serial Number	1202V130
Design Pressure	9756 kPa	Corrosion Allowance	
Radiography	RT-1	Design Temperature	-29C/66C
PWHT	YES	Inlet Deflector	
Float Baffle		Mistex Pad	
Phases	<input type="checkbox"/> 2Phase <input checked="" type="checkbox"/> 3Phase	Additional	
2.0 VESSEL CONNECTIONS			
Inlet	4"-600#	Drain	2"-600#
Gas Outlet	4"-600#	HC Level Control	
H2O Level Control		HC Out	
H2O Level Gauge		HC Level Gauge	
H2O Out		PI	
PSV	2"-600#	TI	
Inspection		HLSD	
Manway	20"-600#	Additional	

Drawings Available	YES <input type="checkbox"/>	NO <input checked="" type="checkbox"/>
--------------------	------------------------------	--

Notes: MISSING OUTER MANWAY NUTS SA 510 TON HEADS/SHELL

Form Completed By/Date:		Approved For Entry/ Date:	
-------------------------	--	---------------------------	--



**ASPIRE ENERGY
RESOURCES INC.**

53 Burnt Lake Crescent, Red Deer, AB T4S 0K6
Telephone: (403) 314-5422 Fax: (403) 314-1823

Inspection Check List - Horizontal Separator

Sweet

Alberta Sour

Sour

Job # _____
A # 2937337
SN # 1202V130
CRN # M2091.2
RT Required RT-1

Inventory # B2102
Size 48" ID / 52.6" OD ID or OD
Type HORIZONTAL SEP.
M.A.W.P. 9756 kPa
C.A. _____

UNIT INSPECTION ITEM	Y	N	Insp Initial	COMMENT
Data Report Received In File	<input type="checkbox"/>	<input type="checkbox"/>		
Nameplate In Good Shape	<input checked="" type="checkbox"/>	<input type="checkbox"/>	DR	
Verify Material Type (ie. 515-70 or 516-70)	<input checked="" type="checkbox"/>	<input type="checkbox"/>		516-70
UT Complete	<input type="checkbox"/>	<input type="checkbox"/>		
Calculations Complete (In-House)	<input type="checkbox"/>	<input type="checkbox"/>		
Pictures Taken Prior to Any Work	<input type="checkbox"/>	<input type="checkbox"/>		
Bake Out Required	<input type="checkbox"/>	<input type="checkbox"/>		
PWHT Required by Code	<input type="checkbox"/>	<input type="checkbox"/>		(Over 1.5" YES PWHT Req'd) (1.25"-1.5" NO PWHT Req'd, Preheat to 200°F) (Under 1.25" NO PWHT Req'd)
PWHT Required for Job (Wendell / Skye to Confirm)	<input type="checkbox"/>	<input type="checkbox"/>		
Nameplate Removed Prior to PWHT / Bakeout	<input type="checkbox"/>	<input type="checkbox"/>		
Tap & Inspect all TOL's & CPLG's	<input type="checkbox"/>	<input type="checkbox"/>		
Buff & Inspect all Flanges (Damage, Pitting)	<input type="checkbox"/>	<input type="checkbox"/>		
Inspect All Welds	<input type="checkbox"/>	<input type="checkbox"/>		
Inspect Outside (Dents, Damage, Corrosion, Pitting)	<input type="checkbox"/>	<input type="checkbox"/>		
Inspect Inside (Dirt, Scale, Floats, Debris)	<input type="checkbox"/>	<input type="checkbox"/>		
Inspect Internals (Vortex Breakers, Baffles)	<input type="checkbox"/>	<input type="checkbox"/>		
Inspect Mistex	<input type="checkbox"/>	<input type="checkbox"/>		
Check for Broken Internal Bolts	<input type="checkbox"/>	<input type="checkbox"/>		
Check Threads on Internal Bolts (Nut Ends If Coated)	<input type="checkbox"/>	<input type="checkbox"/>		
Oil Boxes and Compartments Fully Cleaned	<input type="checkbox"/>	<input type="checkbox"/>		
All Necessary Vessel Connections Exist	<input type="checkbox"/>	<input type="checkbox"/>		
Connections Labeled with Paint Marker	<input type="checkbox"/>	<input type="checkbox"/>		
Connections match P&ID	<input type="checkbox"/>	<input type="checkbox"/>		
Hydro Test Any Coils (Take Pictures)	<input type="checkbox"/>	<input type="checkbox"/>		
Measure Diameter & Overall Length Of Vessel	<input checked="" type="checkbox"/>	<input type="checkbox"/>	DR	
Vessel Orientation & Elevation Views Completed	<input checked="" type="checkbox"/>	<input type="checkbox"/>	DR	
Removable Internals Taken Out Before Coating	<input type="checkbox"/>	<input type="checkbox"/>		
Studs Removed From Flanges Before Coating	<input type="checkbox"/>	<input type="checkbox"/>		
Ship Loose Internals Labeled and Pictures Taken Prior to Coating	<input type="checkbox"/>	<input type="checkbox"/>		
Manway Covers / Davit Arms Accounted For	<input type="checkbox"/>	<input type="checkbox"/>		
Manway Gasket / Bolt Up Present	<input type="checkbox"/>	<input type="checkbox"/>		
Bolt Up Picked / Ordered (Studs, Nuts & Gaskets)	<input type="checkbox"/>	<input type="checkbox"/>		
Hydro Blinds Picked / Ordered	<input type="checkbox"/>	<input type="checkbox"/>		
3rd Party Inspection Required	<input type="checkbox"/>	<input type="checkbox"/>		



**ASPIRE ENERGY
RESOURCES INC.**

53 Burnt Lake Crescent, Red Deer, AB T4S 0K6
Telephone: (403) 314-5422 Fax: (403) 314-1823

B2102

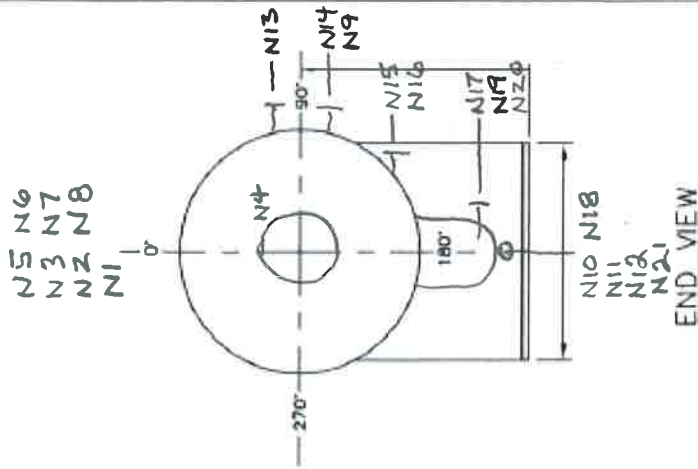

END VIEW

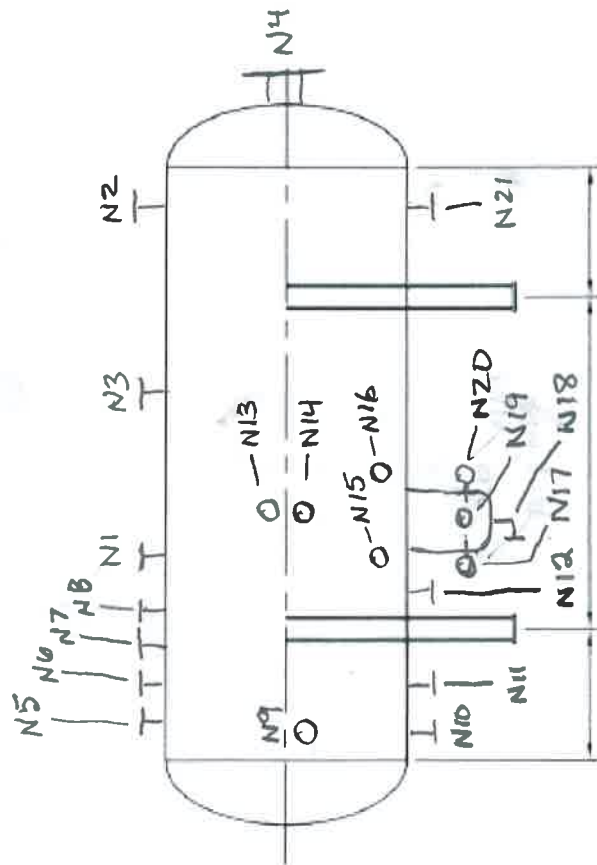

ELEVATION VIEW

CONNECTION SCHEDULE

MARK	SIZE	SCH	CLASS	TYPE	SERVICE
N1	4"	XXS	600	RF	INLET
N2	4"	XXS	600	RF	GAS OUTLET
N3	2"	XXS	600	RF	PSV
N4	20"		600	RF	MANWAY
N5	2"	XXS	600	RF	
N6	1 1/2"	XXS	600	RF	
N7	1 1/2"	XXS	600	RF	
N8	1 1/2"	XXS	600	RF	
N9	2"	XXS	600	RF	
N10	2"	XXS	600	RF	
N11	1 1/2"	XXS	600	RF	
N12	1 1/2"	XXS	600	RF	
N13	1 1/2"	XXS	600	RF	
N14	1 1/2"	XXS	600	RF	
N15	1 1/2"	XXS	600	RF	
N16	1 1/2"	XXS	600	RF	
N17	1 1/2"	XXS	600	RF	
N18	2"	XXS	600	RF	DRAIN
N19	2"	XXS	600	RF	
N20	1 1/2"	XXS	600	RF	
N21	2"	XXS	600	RF	

BILL OF MATERIALS

ITEM	QTY	DESCRIPTION
1	2	HEADS -
2	1	SHELL -
3		
4		
5		
6		
7		
8		
9		
10		
11		
12		